



The
University
Of
Sheffield.



DEEP BOREHOLES: A 21ST CENTURY SOLUTION FOR HIGH-LEVEL RADIOACTIVE WASTES

Prof. Fergus G.F. Gibb, BSc, PhD. FGS

*Immobilisation Science Laboratory,
Department of Materials Science & Engineering, University of Sheffield*

Spent Fuel & other High-Level Wastes

- *Can not be left for future generations to deal with.*
- *New nuclear power plants should not be built without a disposal route for these wastes.*

Swedish KBS-3 repository in granite/gneiss

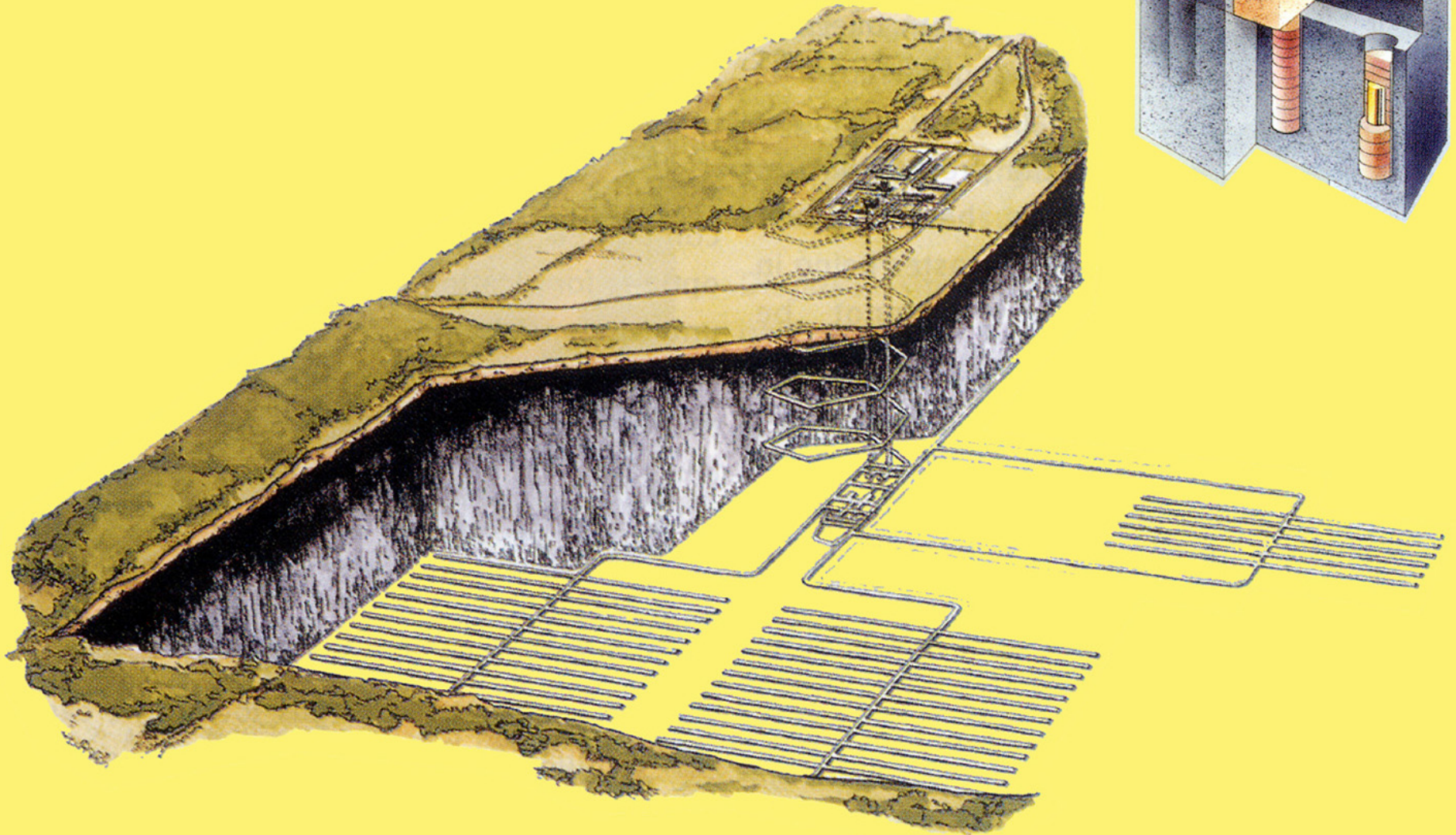

Over 70 years after Spent Fuel and HLW were first produced –

Why is there no repository for these wastes operating anywhere in the world?

- 1. Major Technical, Political & Socio-economic Problems**
- 2. Repositories are usually below the water table and, at depths of only a few hundred metres, are in the zone of near-surface circulating groundwaters.**

Advantages of Deep Boreholes

1. **SAFETY** (Massive geological barrier)
2. **COST-EFFECTIVENESS** (< \$60 M per 5 km hole)

COST COMPARISON

SKB's KBS-3 (Forsmark) *

Cost of construction	=	US \$ 4604.6 M
Cost of 45 years operation	=	US \$ <u>2441.3 M</u>
Total	=	US \$ 7045.9 M
Capacity	=	12,000 tons SF
Spent fuel disposal cost per ton of heavy metal	=	US \$ 587,158

* Data from SKB's application to the Environmental Court

Deep Borehole Disposal *

Cost of one 5 km deep, 0.6 m diameter borehole	=	US \$ 60 M
Capacity (431 containers with fuel rod consolidation)	=	619.6 tons SF
Spent fuel disposal cost per ton of heavy metal	=	US \$ 96,836

* Data from Beswick, Gibb & Travis (2014)

Disposal of SF in deep boreholes costs 16.5% of disposal in a mined repository.

Advantages of Deep Boreholes

1. **SAFETY** (Massive geological barrier)
2. **COST- EFFECTIVENESS** (< \$60 M per 5 km hole)
3. **EASIER SITING** (More geologically suitable sites)
4. **EARLY IMPLEMENTATION** (Possibly < 10 years)
5. **DISPERSED DISPOSAL** (Option of many small sites)
6. **SECURITY** (Covert recovery impossible)
7. **INSENSITIVE to Composition & Heat Output**
8. **ENVIRONMENTAL IMPACT** (Minimal & transient)
9. **FLEXIBILITY** ('Pay as you go')
10. **LONGEVITY** (Rocks & geological structures last billions of years)
11. **SMALL 'FOOTPRINT'** (Tiny area)
12. **EARTHQUAKE 'PROOF'** (Intra-rock fluids unaffected by shear)

Is DBD the ideal solution for the 21st century ?

DBD Technical Challenges & Solutions

- 1. Drilling the borehole**
- 2. Deploying the waste packages**
- 3. Sealing in & supporting the waste packages**
- 4. Sealing the borehole**

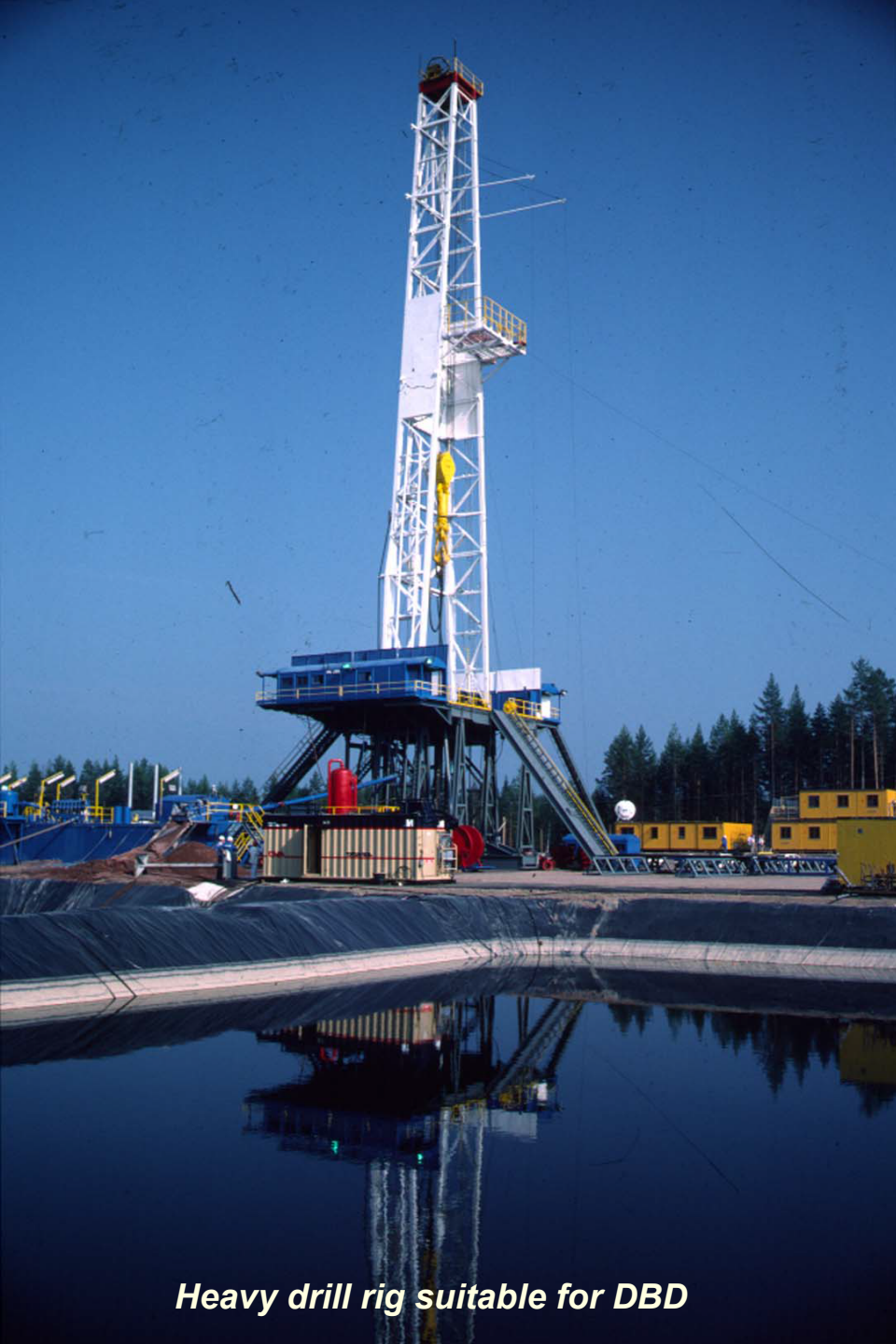

1. Drilling the Borehole

How deep ?

4 to 5 km

How big ?

Depends on the size of the waste packages, i.e. on the outside diameter of the steel container ... *i.e. on what is inside the package*

Heavy drill rig suitable for DBD

Waste Packages

Spent Nuclear Fuel

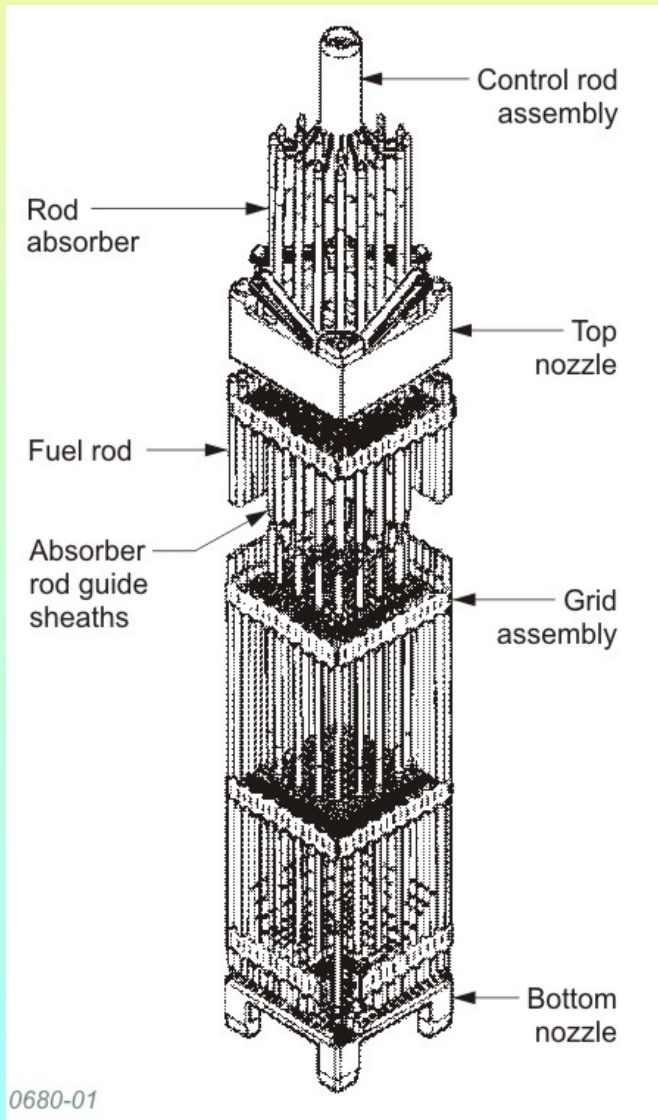

<u>Assemblies</u>			<u>Container</u>	
<i>No.</i>	<i>Type</i>	<i>Rods</i>	<i>ID (m)</i>	<i>OD (m)</i>
1	BWR	74	0.198	0.238
1	PWR	264 825	0.320	0.360
3	BWR	222 1070	0.365	0.405

Fuel Rod CONSOLIDATION

Waste Packages

Vitrified Reprocessing Waste

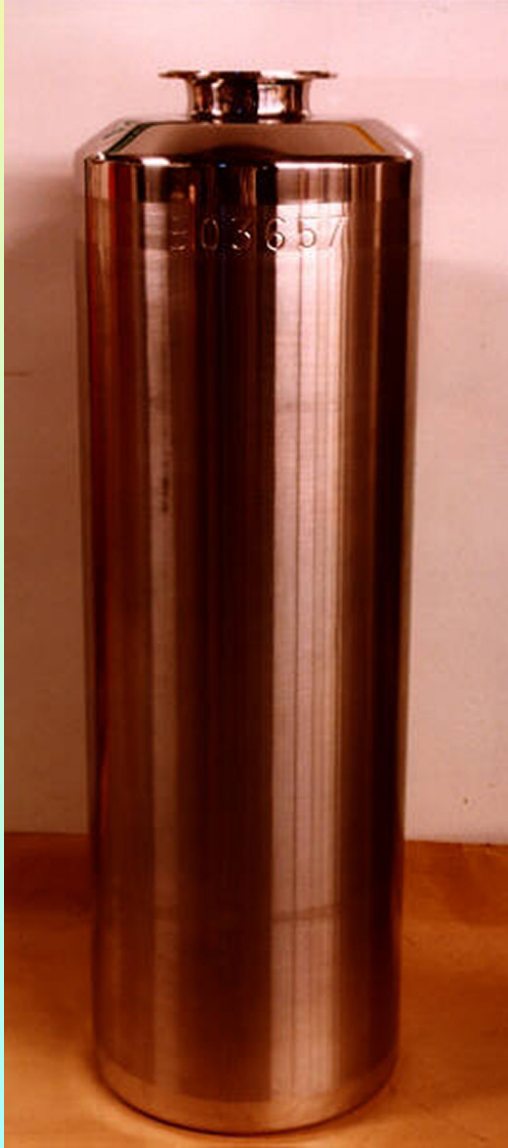

Stainless steel container used for vitrified HLW produced at Sellafield (UK) & La Hague (France).

Height = 1.35 m

O.D. = 0.43 m

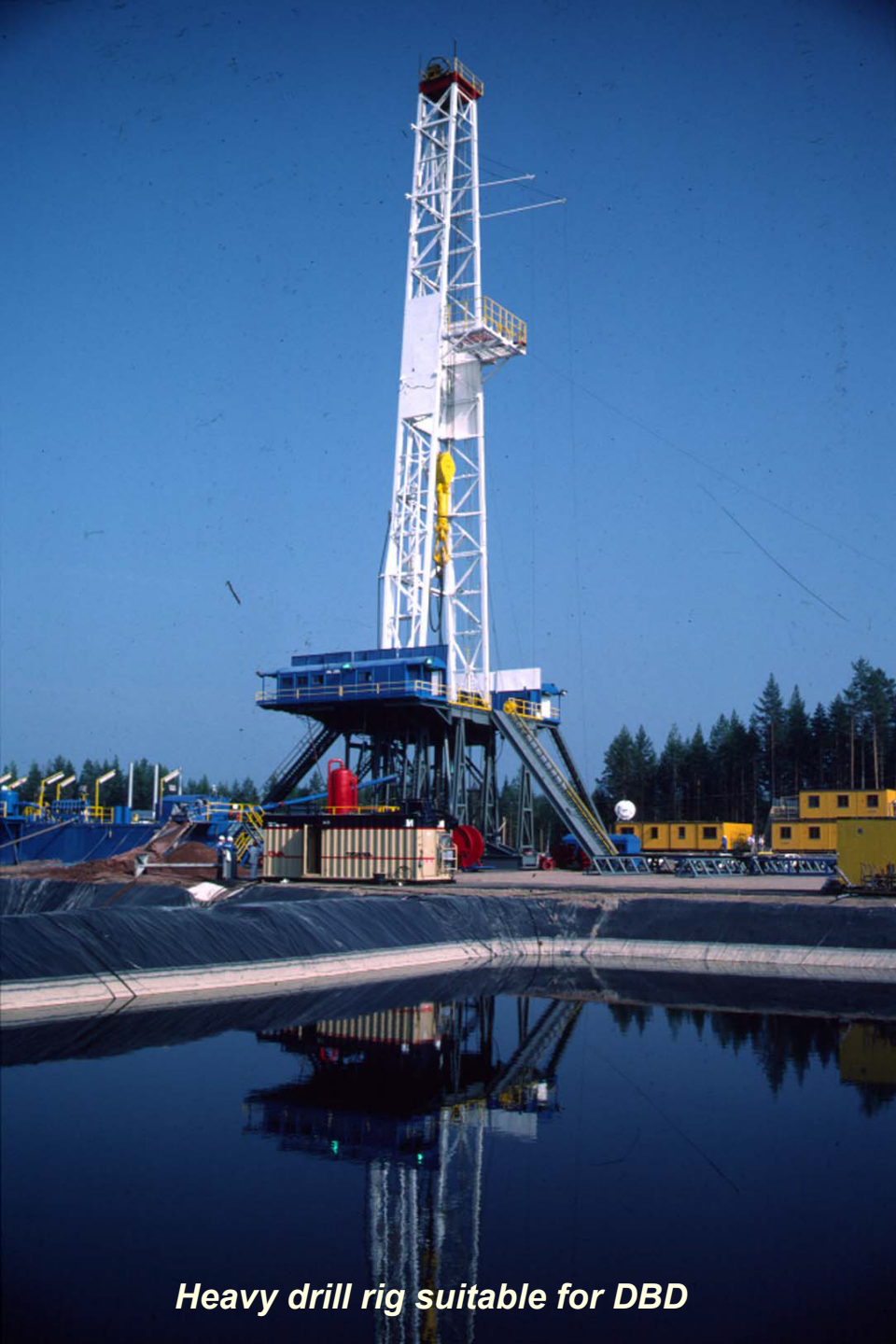

Heavy drill rig suitable for DBD

1. Drilling the Borehole

How deep ?

4 to 5 km

How big ?

Depends on the size of the waste packages, i.e. on the outside diameter of the steel container.

Allowing for casing & clearances -

Borehole Diameter

For Spent Fuel = 0.56 m

For HLW = 0.66 m

Historic Deep Boreholes

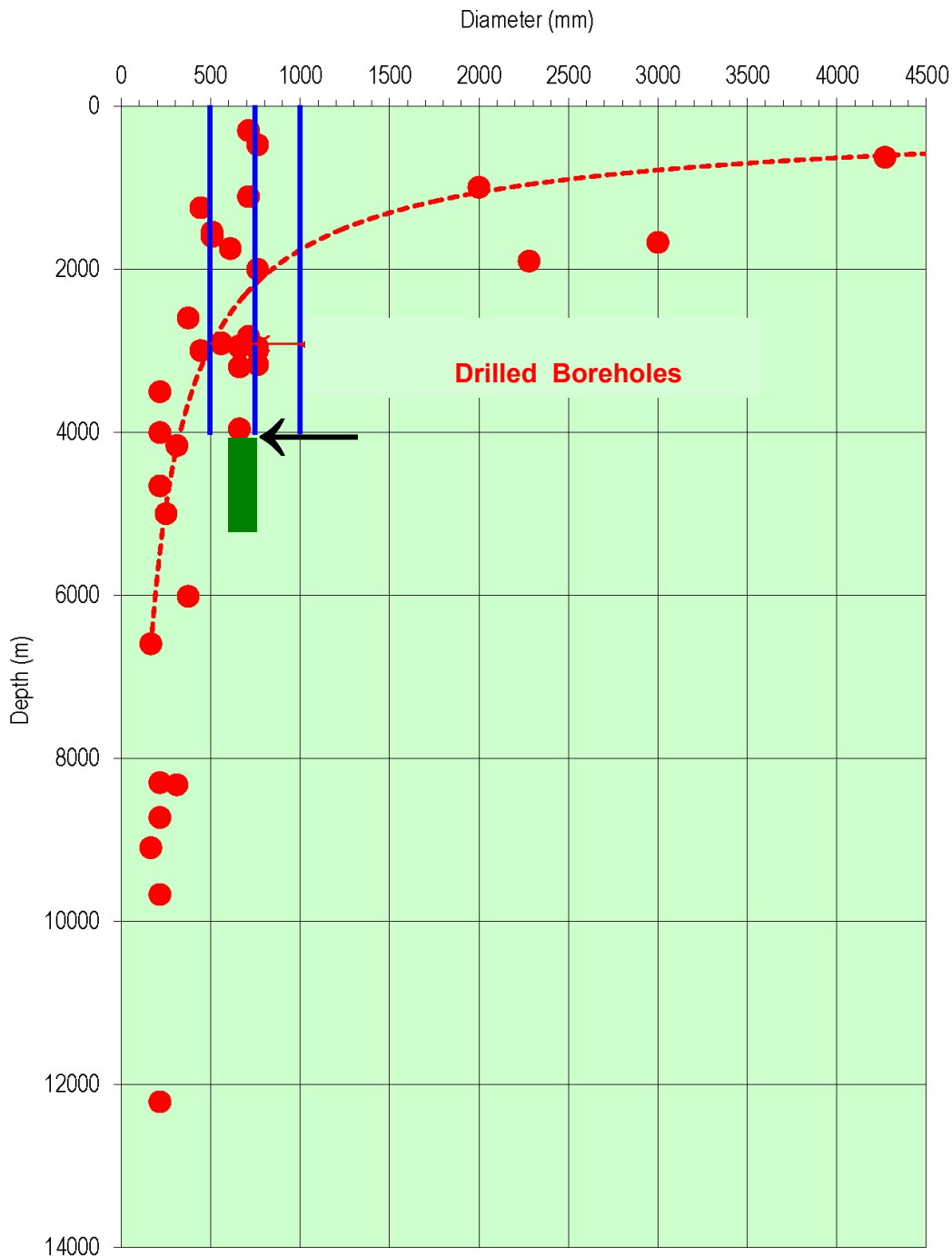

Target = 0.66 m to 4 or 5 km

Louisiana (1984)
0.66 m to 3.81 km

The target is challenging but can be achieved using existing technology with only minor modifications.

Need demonstration borehole !

2. Deployment of Waste Packages

Key factor:

Time required to deliver a package to the disposal zone, recover the delivery equipment & ready it for the next emplacement (= “round trip” time)

Emplacement Mechanisms:

- 1. Free fall** *Insufficient control*
- 2. Wireline** *Weight restrictions; Risk of ‘hang-ups’ & loss of time*
- 3. Drill pipe** *No weight limit; Good depth control; Slow; Ties up drill rig*
- 4. Coiled tubing**

Down-hole Deployment using Coiled Tubing



2. Deployment of Waste Packages

Key factor:

Time required to deliver a package to the disposal zone, recover the delivery equipment & ready it for the next emplacement (= “round trip” time)

Emplacement Mechanisms:

Round trip times

- | | | |
|-------------------------|---|-----------------|
| 1. Free fall | <i>Insufficient control</i> | n/a |
| 2. Wireline | <i>Weight restrictions; Risk of ‘hang-ups’ & loss of time</i> | 8 hours |
| 3. Drill pipe | <i>No weight limit; Good depth control; Slow; Ties up drill rig</i> | 18 hours |
| 4. Coiled tubing | <i>No weight limit; Monitoring; Depth control; Fast; Frees up drill rig</i> | 8 hours |

Coiled tubing is the preferred method

3. Sealing & Support Matrices (SSM)

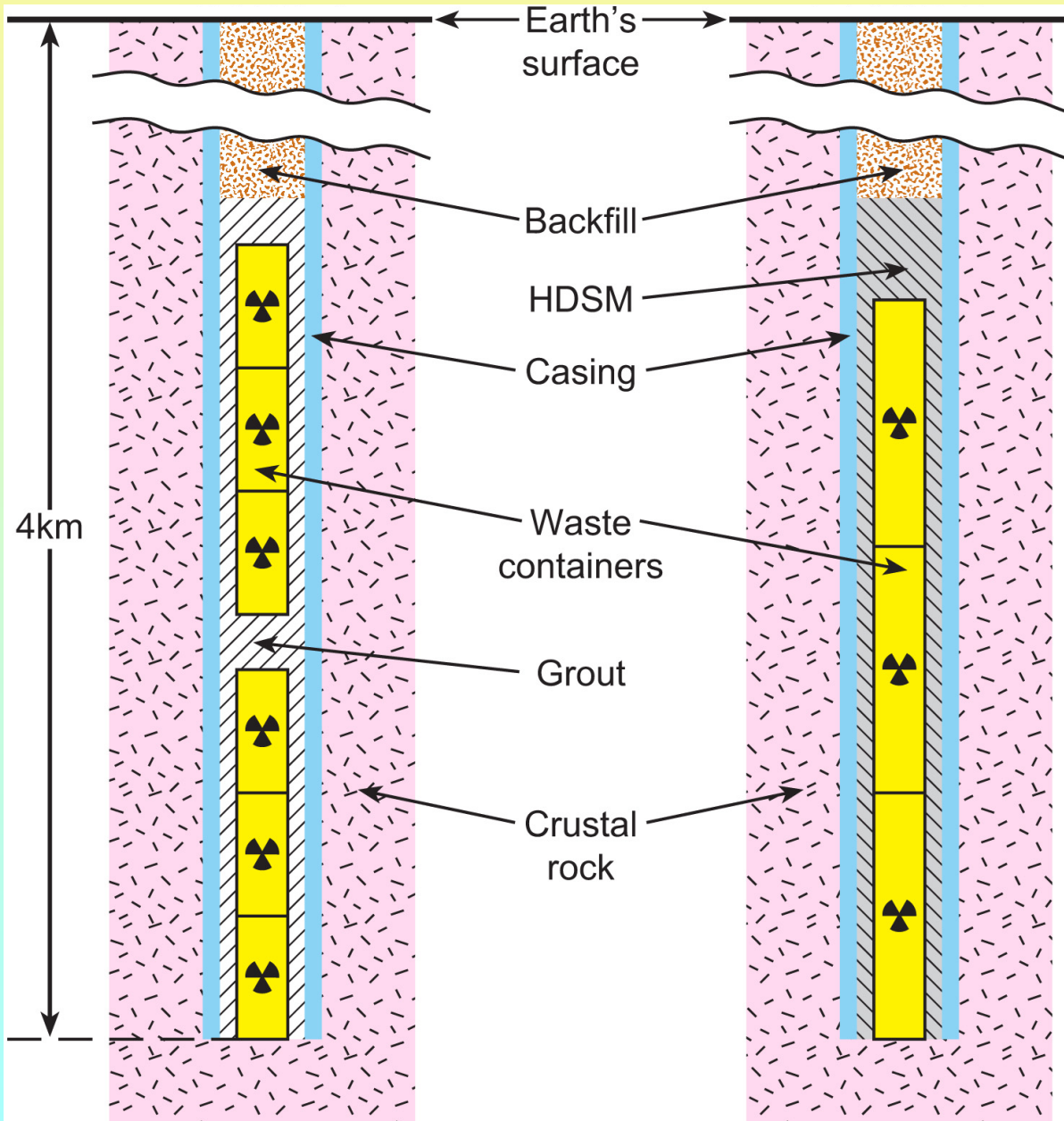

Protect containers from premature corrosion by saline groundwaters

Support containers against load damage from overlying stack of waste packages.

Options:

1. High-density support matrix (HDSM), $T^{\circ} > 190^{\circ}\text{C}$

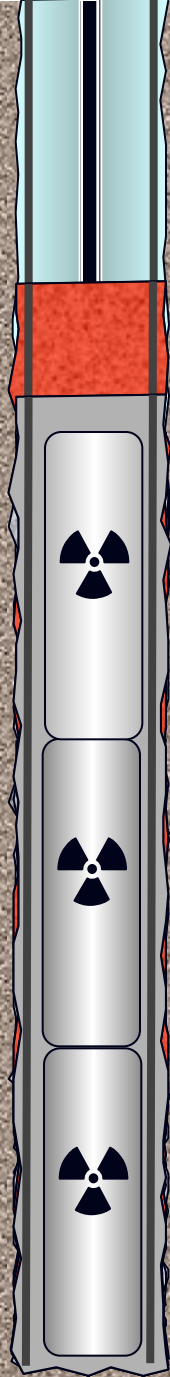

Deep borehole disposal of waste generating moderate T°s

E.g. Young spent fuels or MOX

(Annulus T° 190°C to ~ 300°C)

- ☺ Borehole cased to TD > 4km.
- ☺ Emplace first container using drill-pipe or coiled tubing.
- ☺ Immediately followed by release of HDSM (Pb alloy shot) to fill annulus.
- ☺ Insert the rest of the containers at intervals each + HDSM then add extra HDSM (“head”).
- ☺ The HDSM melts, settles into the annulus & eventually solidifies – *effectively “soldering” the packages into the borehole.*

Schematic Cross Section of Borehole

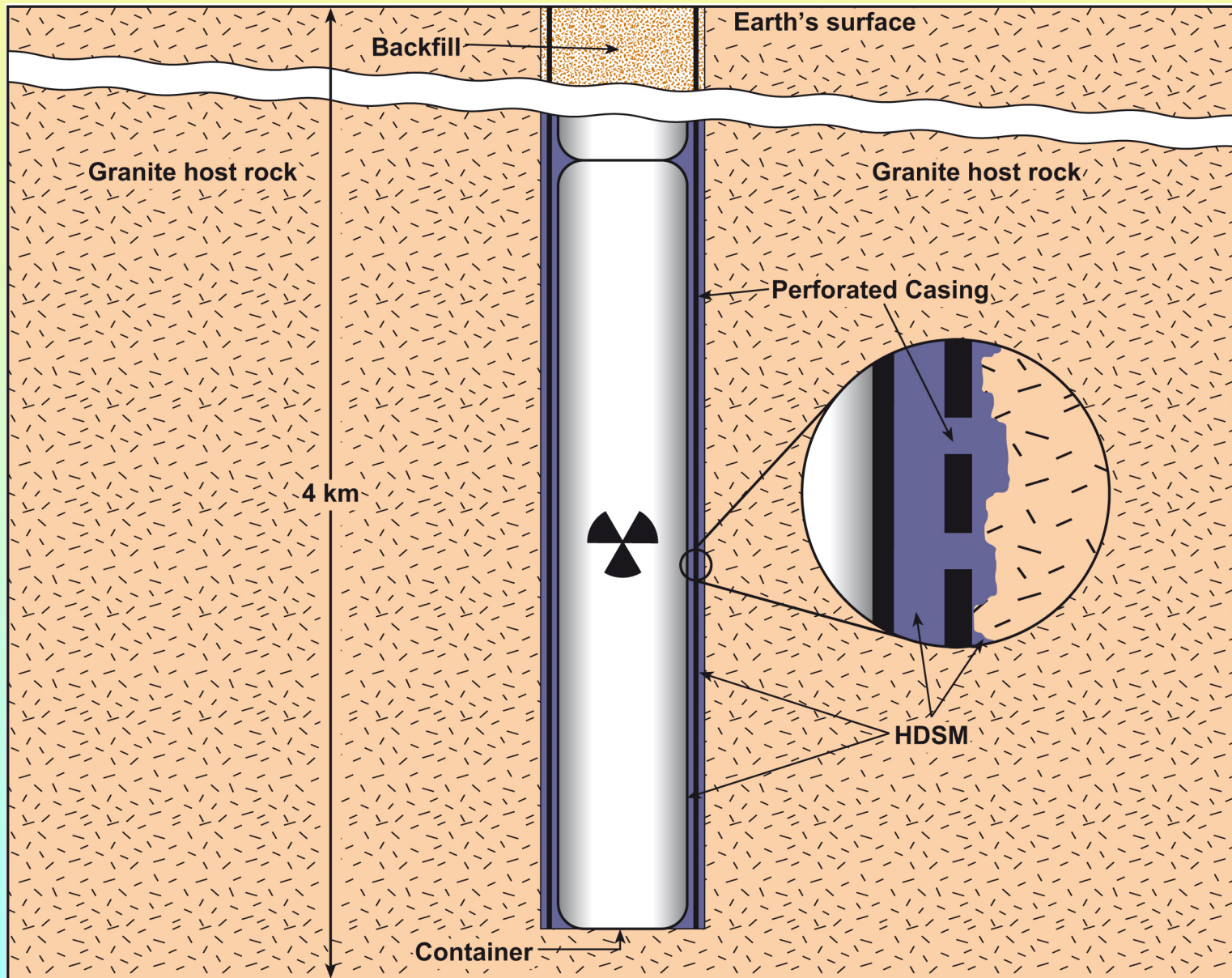

3. Sealing & Support Matrices (SSM)

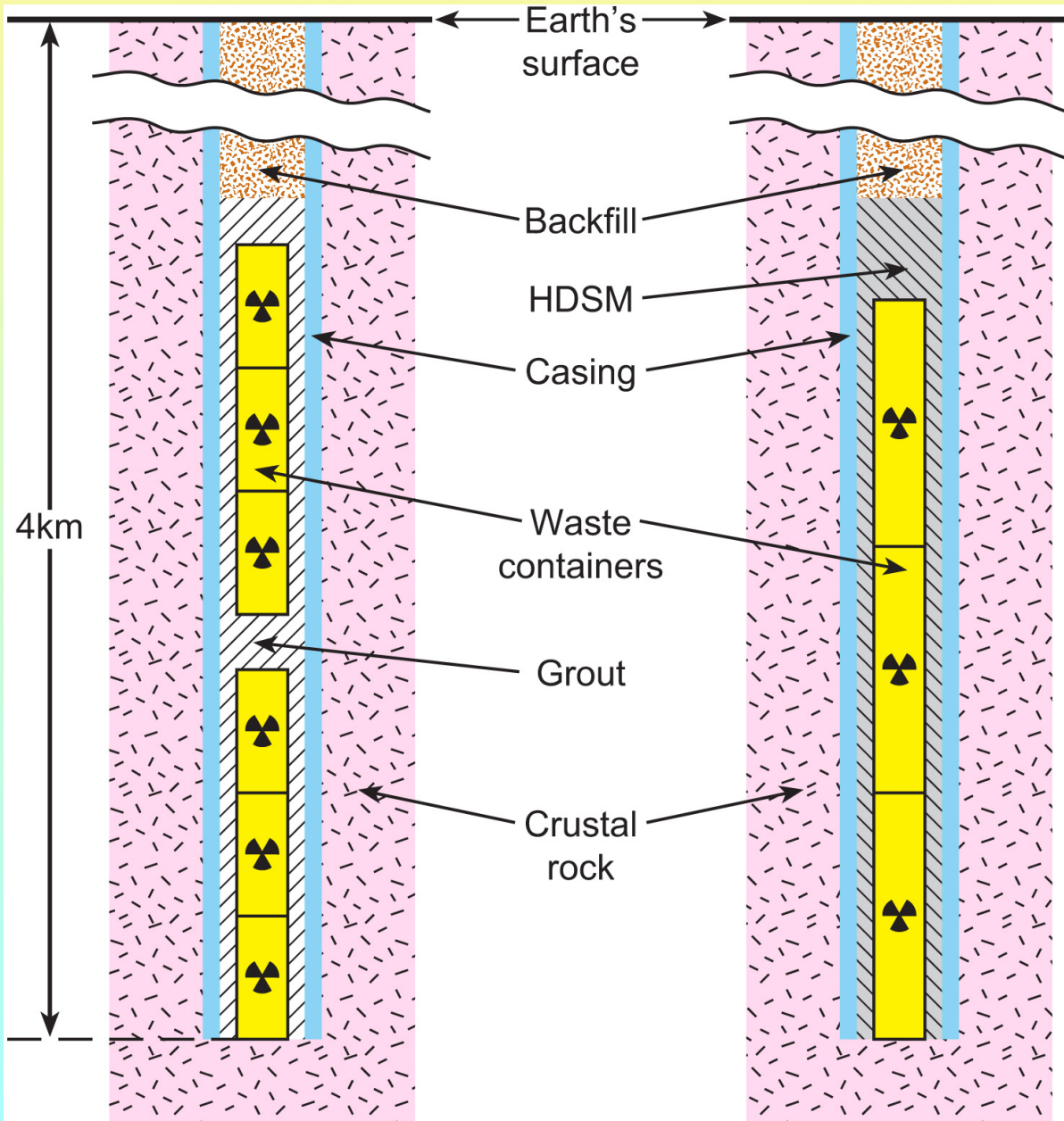

Protect containers from corrosion by saline groundwaters

Support containers against load damage from overlying stack of waste packages.

Options:

1. **High-density support matrix (HDSM), $T^{\circ} > 190^{\circ}\text{C}$**
2. **Cement grout, $T^{\circ} < 190^{\circ}\text{C}$**
 - i). As for geothermal wells
 - ii). Custom formulation

4. Sealing the Borehole Above the DZ (Disposal Zone) = *The “main” seal(s)*

- *Essential the borehole does not provide an easier route to the surface than the enclosing geology for any fluids carrying radionuclides*
- *The borehole must be completely & permanently sealed above the uppermost waste package*

Sealing the Borehole by “conventional” methods

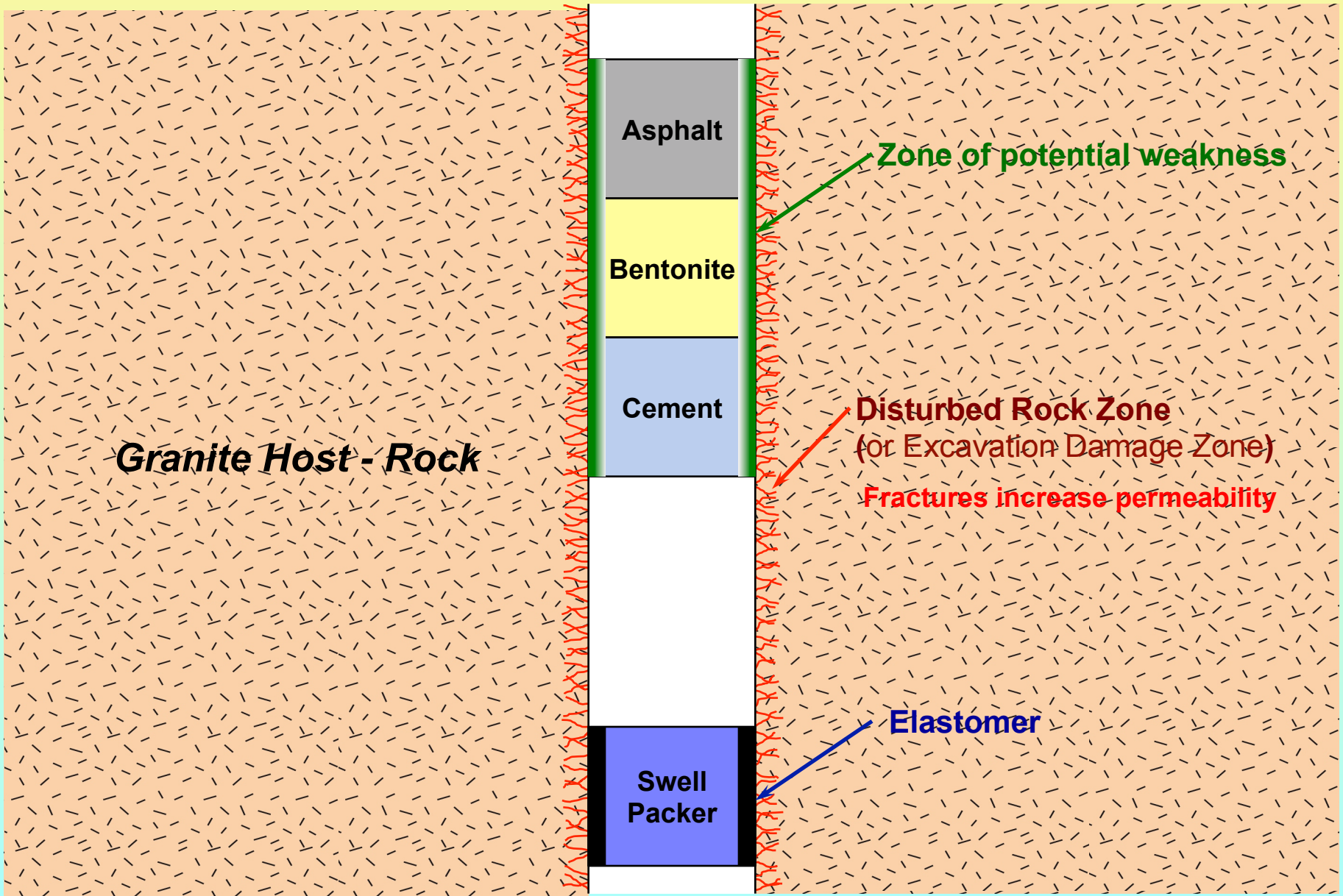

Rock-welding Engineering Concept

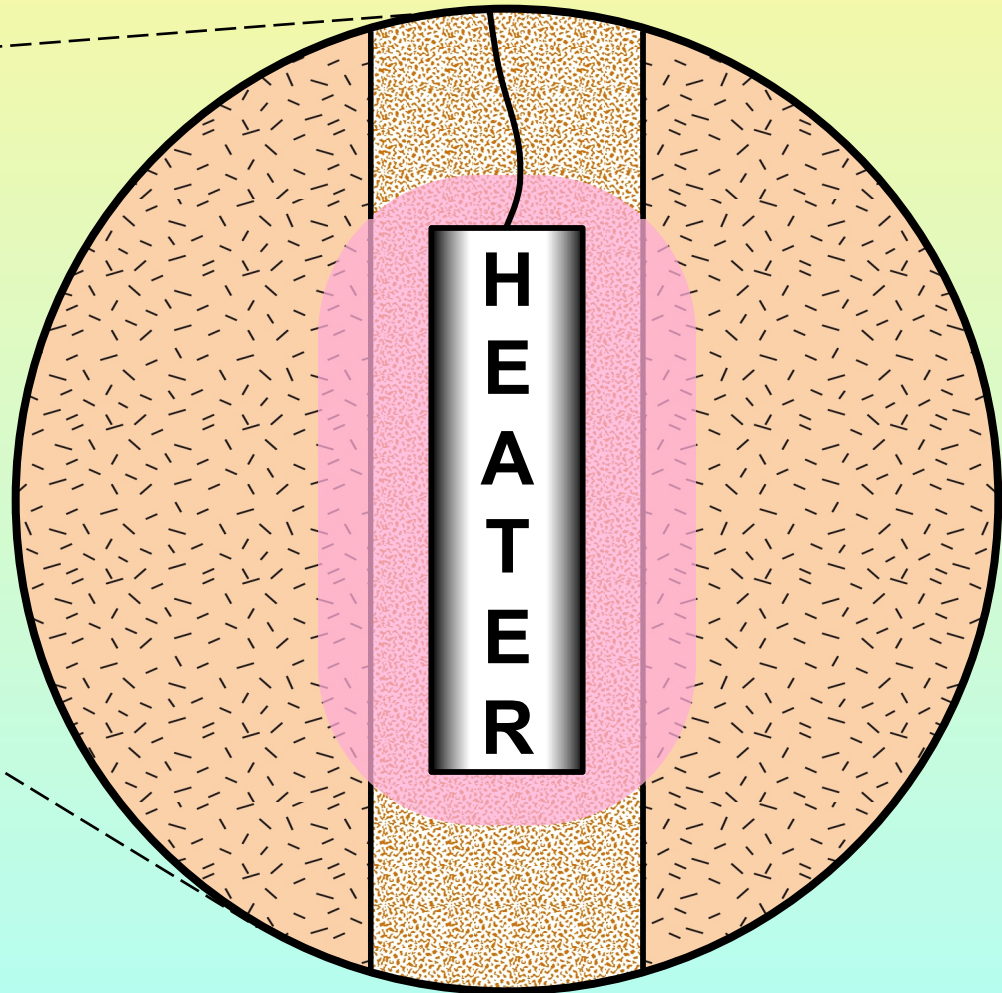
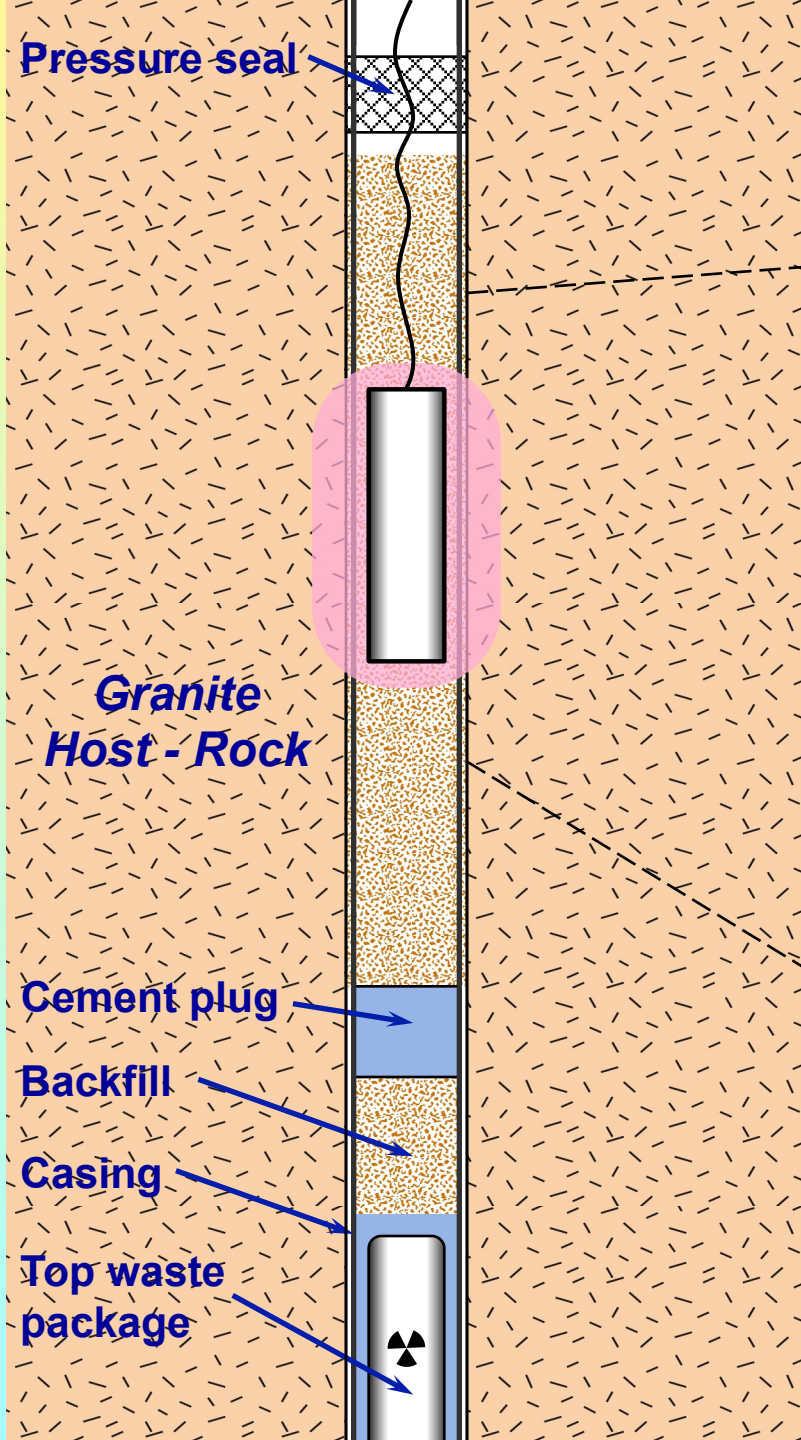

NOT TO SCALE

“Hollow cylinder” Heater

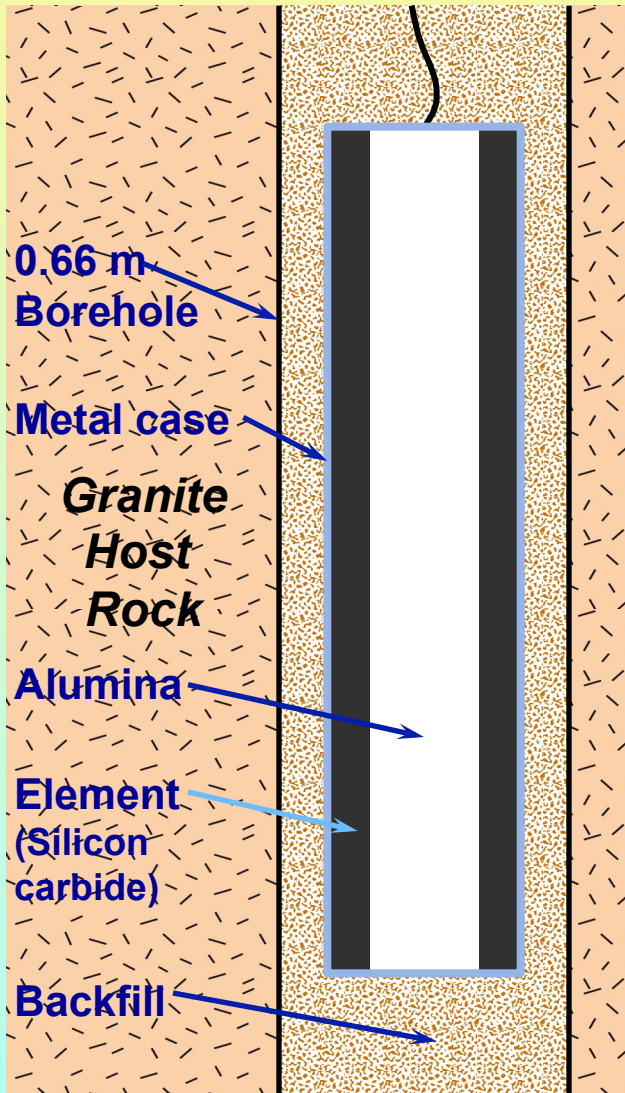

Length = 2 m

Diam. = 0.46 m

Power Input
= 12kW

Heat Output
= 54.8 kWm⁻³

Distribution
= Annular

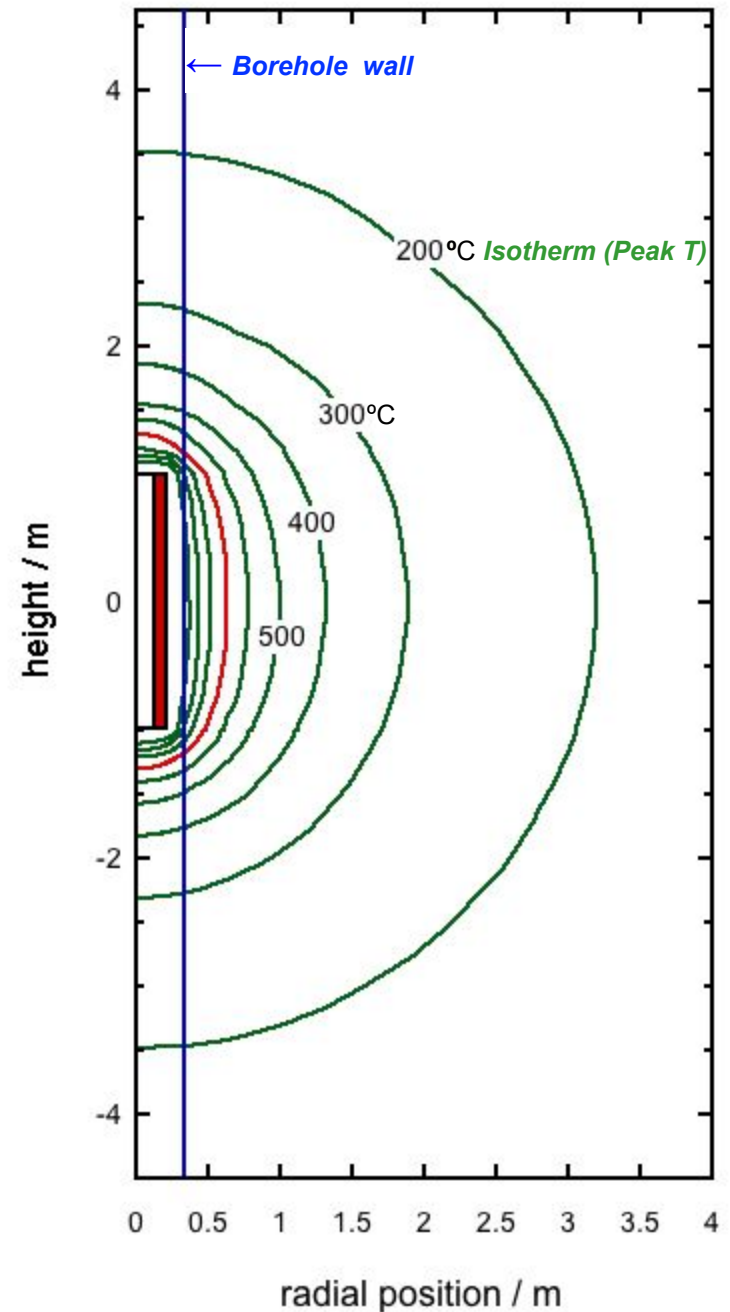

SUMMARY & CONCLUSION

- **DBD is potentially a safe, secure, cost-effective and environmentally sound solution for SF & HLW**
- **It offers many advantages over disposal in mined & engineered repositories.**
- **It presents no insurmountable technical or engineering challenges**
 - 1. Boreholes can be drilled now using commercially available technology with only minor development & adaptations*
 - 2. Waste packages can be safely & reliably emplaced (& recovered)*
 - 3. Waste containers can be supported against load damage & protected from premature corrosion by saline groundwaters.*
 - 4. The borehole can be completely & permanently sealed above the disposal zone by “rock welding”*

DBD is a 21st Century solution for SF and other HLW

Developments in USA:

2010 – Federal repository at Yucca Mountain cancelled.

2012 - Presidential Blue Ribbon Commission reported -

” the Commission has identified deep boreholes as a potentially promising technology for geologic disposal that could increase the flexibility of the overall waste management system and therefore merited further research, development and demonstration.”

2012 - US Secretary of Energy accepted the BRC report & the Department of Energy (DOE) is now committed to investigate DBD as an alternative to Yucca Mountain.



Heavy Drill Rig Suitable for Deep Borehole Disposal



THANK YOU